



SPECIFICATION FOR TFT LCD MODULE

MODEL NO: **DST2401PH**

CUSTOMER:

(2.41 INCH SINGLE TFT MODULE)

This module uses ROHS material

Customer Approval:

APPROVED BY
DATE:

ISSUED DATE: 2008/06/17

PREPARED BY	CHECKED BY	APPROVED BY



Contents

1	Introduction-----	4
2	General specification-----	5
3	Mechanical drawing-----	6
4	Absolute maximum ratings-----	7
5	Typical Electrical characteristics-----	7
6	B/L Characteristics-----	7
7	Optical characteristics -----	8
8	Interface Pin Function-----	11
9	Block diagram -----	12
10	Caution -----	13
11	LCM quality criteria-----	13
12	Packing method-----	19



1. Introduction

1.1 Scope of application

This specification applies to the Negative type TFT transmissive dot matrix LCD module that is supplied by **SHENZHEN DISPLAYSUN OPTECH TECHNOLOGY CO., LTD.** This LCD module should be designed for mobile phone use.

LCD specification: Duty 1/320, Dots 240xRGBx320.

As to basic specification of the driver IC, refer to the IC (ILI9325) specification and data book.

All material & processing of the LCD module should be Lead Free.

TFT features:

Single display structure (thickness Max3.0mm):

2.41 TFT MODULE+ FPC+BL+TP;

Transmissive Negative Type LCD

240 dot-segment and 320 dot-common outputs;

FULL 262k Color TFT LCD ;

One bare chip with gold bump (COG) TECH;

16BITS 80 parallel series interface;

1.3 Applications:

Mobile phone



2. General specification

<i>ITEM</i>	<i>Standard value</i>	<i>UNIT</i>
LCD type	TFT Negative Transmissive	---
Number of Dots	240(RGB)*320	Dots
Dot Pitch(W*H)	0.153*0.153	mm
Active Area	36.72*48.96	mm
Glass Area(W*H)	40.52*57.46	mm
LCD duty	1/240	
LCD bias	/	
Viewing Direction	12 O'clock	
Controll IC	ILI9325	
Module Size(W*H*T)	42.72*60.26*3.0	mm
APPROX.WEIGHT	TBD	g
Back Light	White LED	



3. Mechanical drawing

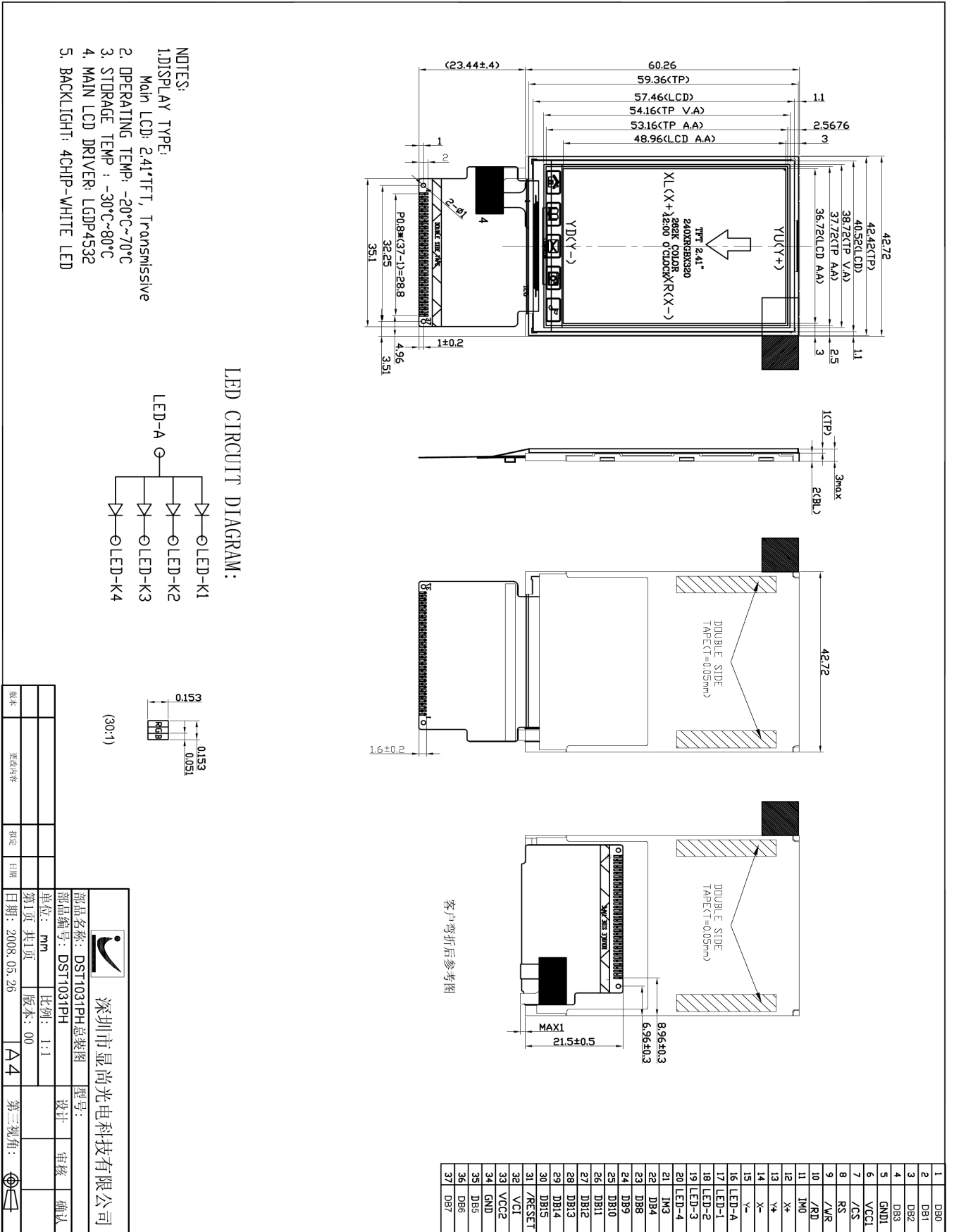



4. Absolute Maximum Ratings

ITEM	SYMBOL	MIN	MAX	UNITS	NOTE
Power Supply Voltage (1)	VDD	-0.3	+4.0	V	
Power Supply Voltage (2)	VGH	+9.0	+16.5	V	
Power Supply Voltage (3)	VGL	-16.5	-4.0	V	
Input Voltage	VI	-0.3	VDD+0.3	V	
Operating Temperature	Topr	-20	70	°C	
Storage Temperature	Tstg	-30	80		

Notes:

1. If the LSI is used above these absolute maximum ratings, it may become permanently damaged. Using the LSI within the following electrical characteristics limit is strongly recommended for normal operation. If these electrical characteristic conditions are also exceeded, the LSI will malfunction and cause poor reliability.
2. VDD, GND must be maintained
3. DC characteristics and AC characteristics of shipping chips and shipping wafer are guaranteed at 85°C.

5. Typical Electrical Characteristics

ITEM	SYMBOL		CONDITIONS	MIN	TYP	MAX	UNITS
Power-supply voltage For LCD	TFT LCD	VGH	At 25°C	9.0	--	16.5	V
		VGL		-16.5	--	-4	
	VDD-GND			-	2.8	3.3	
Input voltage for LCD	V _{IH}		“High” level	0.8VDD	--	VDD	
	V _{IL}		“Low” level	GND	--	0.2VDD	
Supply current for LCD	VDD		VDD=2.8V	--	--	14	mA

Note 1: The supply voltage for VLCD has to be adjusted by software.

6. B/L Characteristics

PARAMETER	SYMBOL	MIN	TYP	MAX	UNIT	CONDITION
Lamp Voltage	V _L	--	3.2	3.3	V	Each ILED=15mA
Back Light	--	3200	--	--	Cd/m ²	

- ※ LEDs in 4- parallel of B/L module
- ※ PWM control.



7. Optical Characteristics

ITEM	SYMBOL	CONDITIONS	SPECIFICATIONS			UNIT	NOTE	
			MIN.	TYP.	MAX			
Brightness	B	Viewing normal angle	150	220	--	cd/m ²		
Contrast Ratio	CR		100	120	--	--		
Response Time	Tr+Tf		--	25	40	ms		
CIE Color coordinate	Red		X _R	--	0.593			
			Y _R		0.333			
	Green		X _G	--	0.314			
			Y _G		0.545			
	Blue		X _B	--	0.138			
			Y _B		0.160			
White	X _w		--	0.314				
	Y _w		0.345					
Viewing Angle	Hor.	θ_{x+}	40	--	--	Deg.		
		θ_{x-}	40	--	--			
	Ver.	θ_{y+}	35	--	--			
		θ_{y-}	15					
Uniformity	Un		80	85		%		

Note 1 : Definition of Viewing Angle θ_x and θ_y :

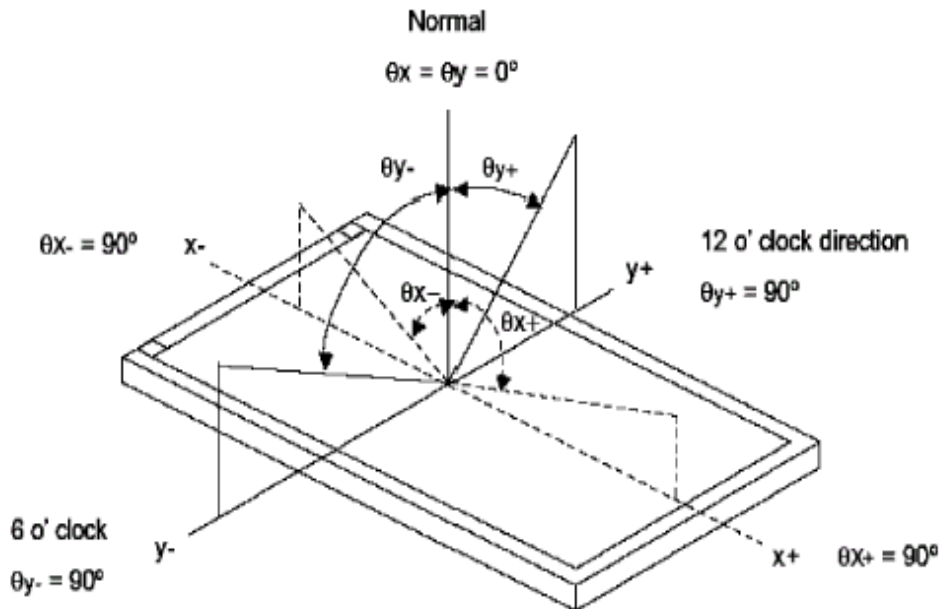



Note 2: Definition of contrast ratio CR:

$$C R = \frac{\text{Brightness of non-selected dots (white)}}{\text{Brightness of selected dots (black)}}$$

Note 3: Definition of response time (T_R , T_F)

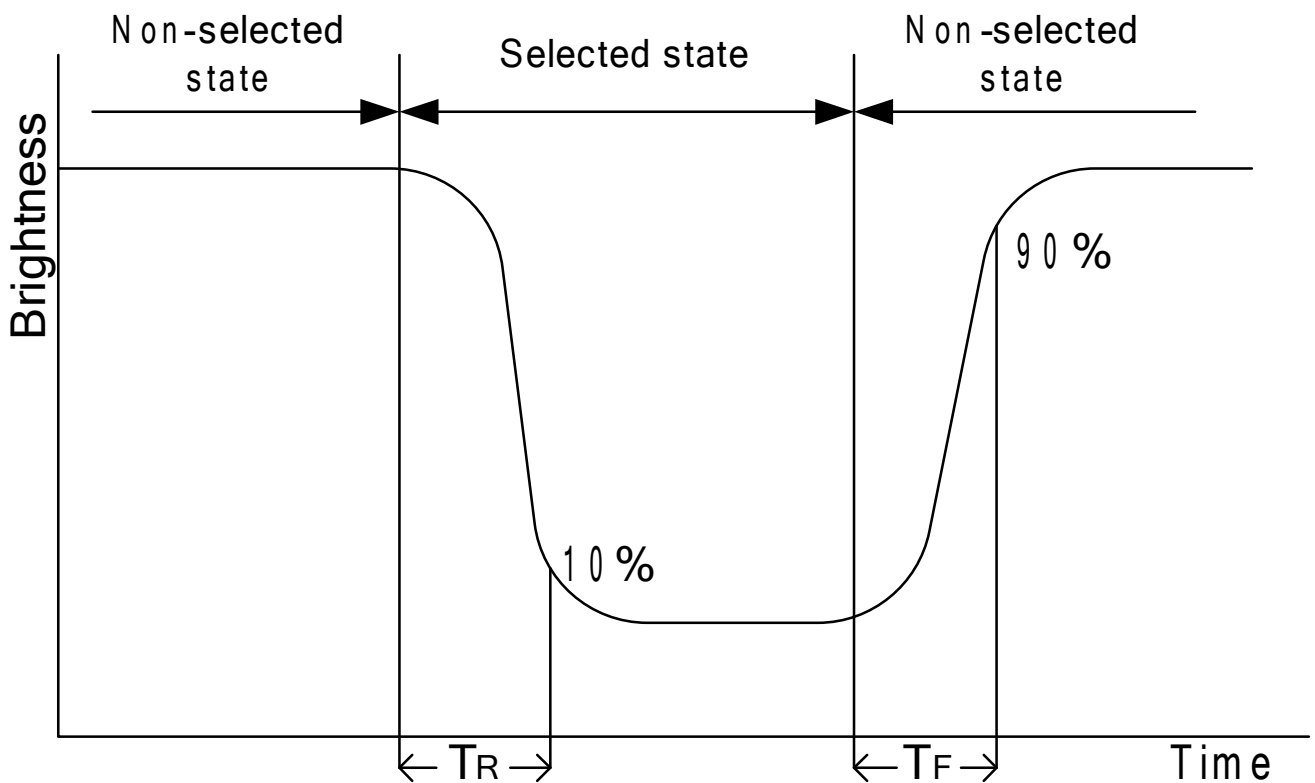



The brightness test equipment setup
20mA Field=2° (As measuring "black" image, field=2° is the best testing condition)

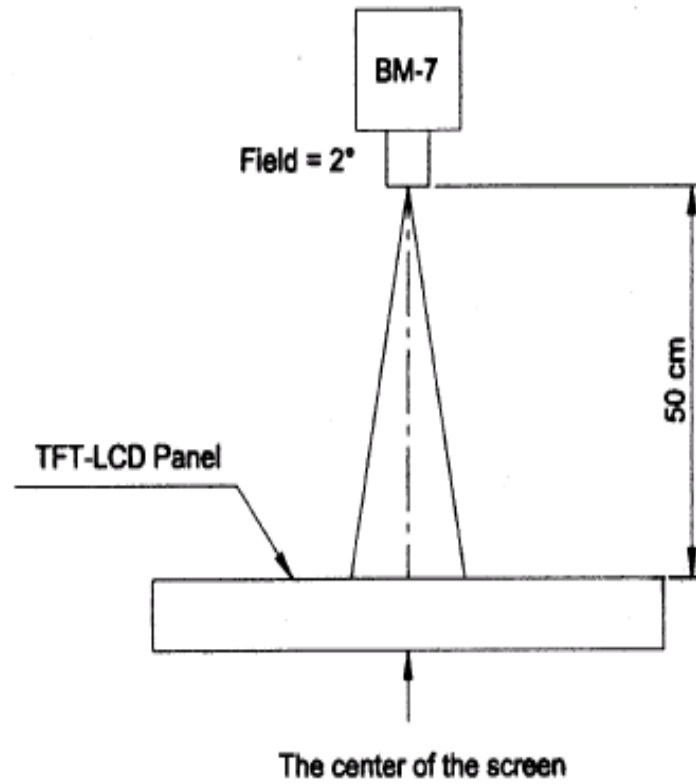

Note 4 :

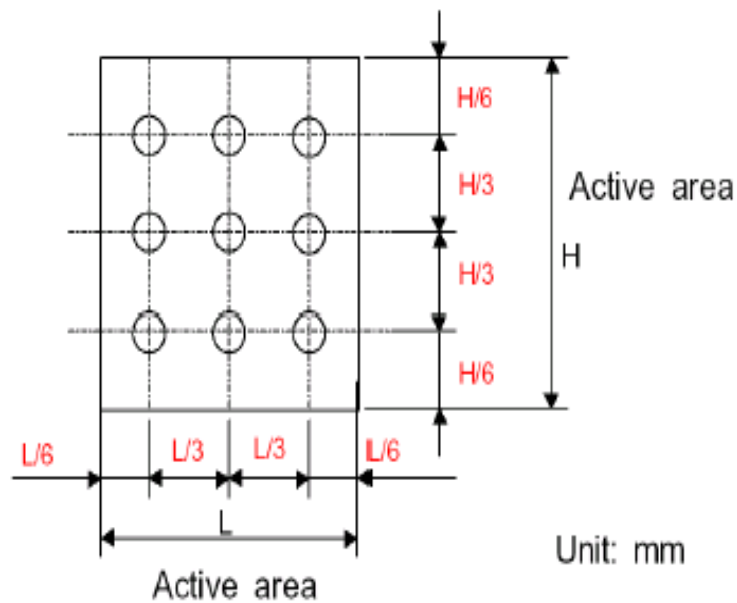



8. Interface Pin Function

NO.	SYMBOL	Description	I/O
1	DB0	Data Bus	I/O
2	DB1	Data Bus	I/O
3	DB2	Data Bus	I/O
4	DB3	Data Bus	I/O
5	GND1	GND	POWER SUPPLY
6	VCC1	A Power supply for the internal logic circuit	POWER SUPPLY
7	/CS	Chip selection input pin: Active "L"	
8	RS	LCD register selector	I
9	/WR	Write	I
10	/RD	Read	I
11	NC	-----	I
12	X+	Touch panel interface	-
13	Y+	Touch panel interface	-
14	X-	Touch panel interface	-
15	Y-	Touch panel interface	-
16	LEDA	Backlight positive input pin	-
17	LEDK1	Backlight negative input pin	-
18	LEDK2	Backlight negative input pin	-
19	LEDK3	Backlight negative input pin	-
20	LEDK4	Backlight negative input pin	-
21	NC	-----	I
22	DB4	Data Bus	I/O
23	DB8	Data Bus	I/O
24	DB9	Data Bus	I/O
25	DB10	Data Bus	I/O
26	DB11	Data Bus	I/O
27	DB12	Data Bus	I/O
28	DB13	Data Bus	I/O
29	DB14	Data Bus	I/O
30	DB15	Data Bus	I/O
31	/RESET	Reset signal: Active "L"	I
32	VCI	A Power supply for step-up circuit and power supply circuit	POWER SUPPLY
33	VCC2	A Power supply for the internal logic circuit	POWER SUPPLY
34	GND	GND	POWER SUPPLY
35	DB5	Data Bus	I/O
36	DB6	Data Bus	I/O
37	DB7	Data Bus	I/O



9. Block Diagram

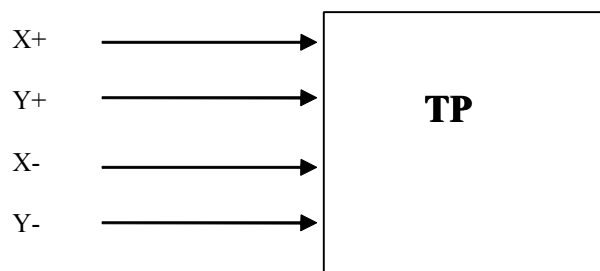
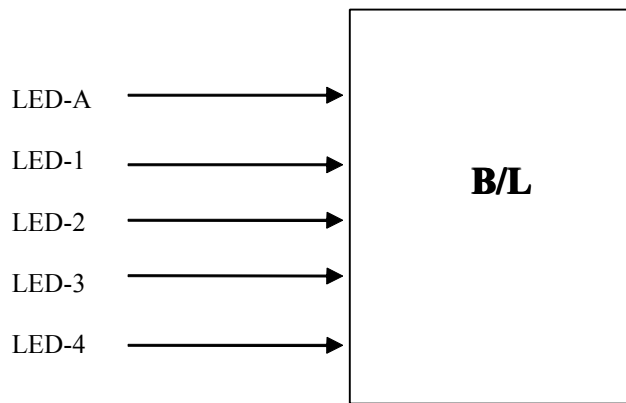
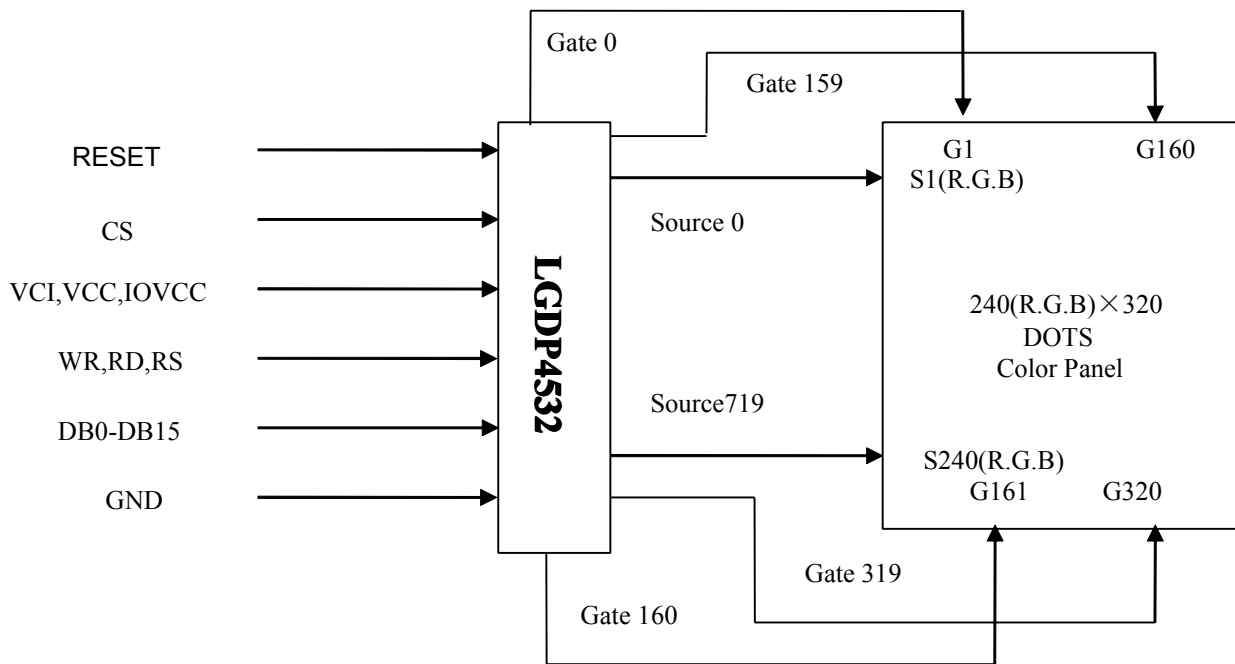



10. Caution

10.1 Handling of LCM

- . Be sure to ground the body when handling the LCM.
- . Don't give external shock
- . Don't apply excessive force on the surface.
- . Liquid in LCD is hazardous substance. Must not lick and swallow.
When the liquid is attach to your hand, skin, cloth etc. Wash it out thoroughly and immediately.
- . Don't operate it above the absolute maximum rating.
- . Don't disassemble the LCM

10.2 Storage

- .Store in an ambient temperature of 5°C to 45°C ,and in a relative humidity of 40% to 60%. Don't expose to sunlight or intensive ultraviolet rays
- . Storage in a clean environment, free from dust, active gas, and solvent.
- . Store in anti-static electricity container.
- . Store without any physical load.

11.LCM Quality Criteria

11.1 RELIABILITY TEST

N O	ITEM	CONDITION	STANDARD
1	High temp. Storage	70 °C, 48hrs	No function failure detected.
2	Low temp. Storage	-20 °C, 48hrs	No function failure detected.
3	High temp. & High humidity operation	60 °C, 90%, 48hrs	No function failure detected.
4	High temp. Operation	60 °C, 48hrs	No function failure detected.
5	Low temp. Operation	-10 °C, 48hrs	No function failure detected.
6	Thermal shock	-20 °C, 30min~70°C, 30min, 10 cycles.	No function failure detected.

The reliability items will be fully performed in new sample qualification.

The reliability status will be tested as monitor during mass production. The individual reliability test shall be managed by lot. Moreover, the individual reliability item shall be decided according reliability plan.

11.2 VISUAL & ELECTRONIC INSPECTION STANDARD



11.2.1 Inspection conditions

Test and measurement are performed under the following conditions, unless otherwise specified.

Test conditions:

Temperature 20+/-15°C

Humidity 65+/-20% RH

Pressure 860~1060 hPa(mm bar)

Viewing Angle: Normal to the Front Surface

Fluorescent lamp: 20w; viewing distance 30~50cm

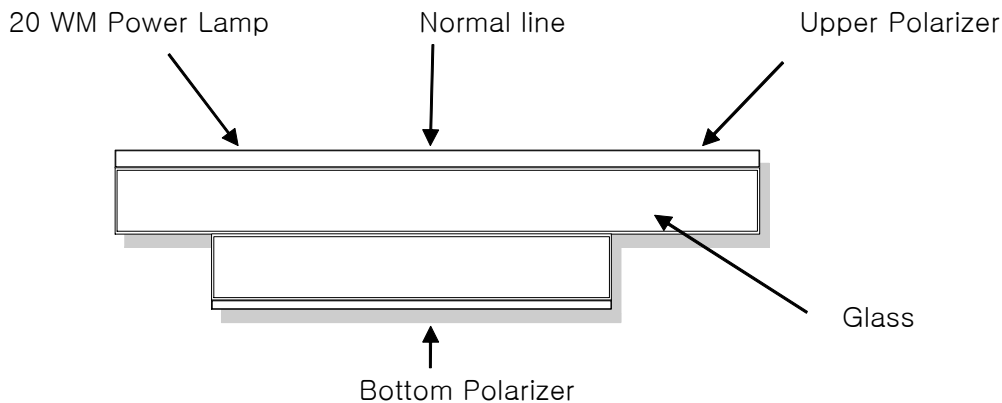

11.2.2 Definition

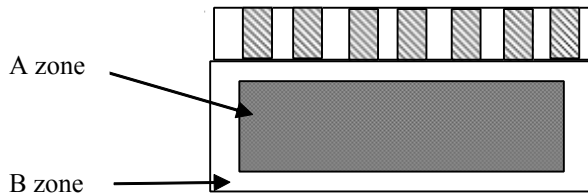

A Zone: Effective Viewing

B Zone: Non-effective Viewing

11.2.3 Quality Level:

According to: ANSI Z 1.4 NORMAL LEVEL II

Major	Minor
0.40	0.65

Major	ITEM	
	Dots	Open, short, miss
Minor	Dots	Pinhole, deformation
	Color tone	Color unevenness, refer to limited sample
	Soldering appearance	Cold solder,



	Polarizing plate	Black spot, white spot, scratch, crack
--	------------------	--

11.2.4 Criteria (Visual)

Number	Items	Criteria (mm)
r		



1.0

Crack

(1) general crack

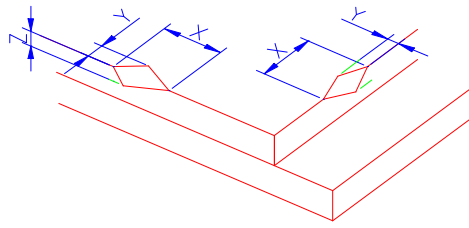

NOTE: ① no effective on A zone.

X : Length

Y : Width

Z : height

L : length of ITO, t : Height of LCD

a : LCD length

X	Y	Z
$\leq 1/8a$	①	T

(2) Corner crack

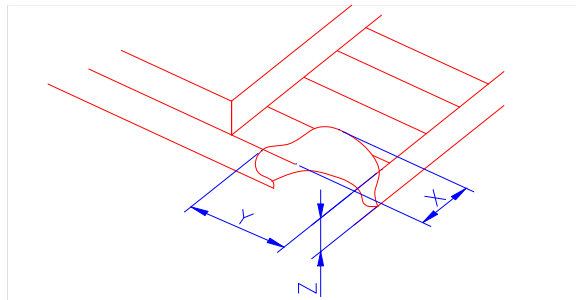

X	Y	Z
$\leq 1/8a$	①	t

(3) ITO pin crack

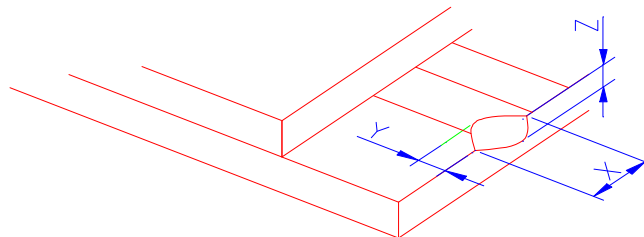

X	Y	Z
$\leq 1/8a$	$1/3L$	Ignore



Number	Items	Criteria (mm)																									
2.0	<p>(4) Seal portion crack</p> <p>Black spots, foreign matter, and white spots (including light leakage due to pinholes of polarizing plates, etc)</p> <p>NOTE: Average diameter $\phi =$ (long diameter + short diameter)/2 $= (A + B)/2$</p>	<p>If $X > a/8$, reject; $W \leq 1/2$ the width of seal, accept.</p> <p>(1) Ring</p> <table border="1"> <thead> <tr> <th>diameter ϕ</th> <th>Acceptable number</th> </tr> </thead> <tbody> <tr> <td>$\phi \leq 0.10$</td> <td>Ignore ①</td> </tr> <tr> <td>$0.10 < \phi \leq 0.20$</td> <td>3</td> </tr> <tr> <td>$0.20 < \phi \leq 0.25$</td> <td>1</td> </tr> <tr> <td>$\phi > 0.25$</td> <td>0</td> </tr> </tbody> </table> <p>(2) line</p> <table border="1"> <thead> <tr> <th>Length</th> <th>Width</th> <th>Acceptable</th> </tr> </thead> <tbody> <tr> <td>$L < 2.0$</td> <td>$W \leq 0.01$</td> <td>Ignore ①</td> </tr> <tr> <td>$L \geq 5.0$</td> <td>$W \leq 0.01$</td> <td>3</td> </tr> <tr> <td>$L \geq 3.0$</td> <td>$0.01 < W \leq 0.05$</td> <td>1</td> </tr> <tr> <td></td> <td>$W > 0.05$</td> <td>0</td> </tr> </tbody> </table>	diameter ϕ	Acceptable number	$\phi \leq 0.10$	Ignore ①	$0.10 < \phi \leq 0.20$	3	$0.20 < \phi \leq 0.25$	1	$\phi > 0.25$	0	Length	Width	Acceptable	$L < 2.0$	$W \leq 0.01$	Ignore ①	$L \geq 5.0$	$W \leq 0.01$	3	$L \geq 3.0$	$0.01 < W \leq 0.05$	1		$W > 0.05$	0
diameter ϕ	Acceptable number																										
$\phi \leq 0.10$	Ignore ①																										
$0.10 < \phi \leq 0.20$	3																										
$0.20 < \phi \leq 0.25$	1																										
$\phi > 0.25$	0																										
Length	Width	Acceptable																									
$L < 2.0$	$W \leq 0.01$	Ignore ①																									
$L \geq 5.0$	$W \leq 0.01$	3																									
$L \geq 3.0$	$0.01 < W \leq 0.05$	1																									
	$W > 0.05$	0																									
3.0	<p>Bubble on polarizing plates</p>	<p>Note : ① To be concentrated, will be rejected.</p> <table border="1"> <thead> <tr> <th>diameter ϕ</th> <th>Acceptable number</th> </tr> </thead> <tbody> <tr> <td>$\phi \leq 0.50$</td> <td>Ignore</td> </tr> <tr> <td>$0.50 < \phi \leq 1.0$</td> <td>2</td> </tr> <tr> <td>$\phi > 1.0$</td> <td>0</td> </tr> </tbody> </table>	diameter ϕ	Acceptable number	$\phi \leq 0.50$	Ignore	$0.50 < \phi \leq 1.0$	2	$\phi > 1.0$	0																	
diameter ϕ	Acceptable number																										
$\phi \leq 0.50$	Ignore																										
$0.50 < \phi \leq 1.0$	2																										
$\phi > 1.0$	0																										



4.0	Scratch	<p>1.0 scratch for LCD</p> <table border="1" data-bbox="628 412 1230 636"> <thead> <tr> <th>Length</th> <th>Width</th> <th>Acceptable</th> </tr> </thead> <tbody> <tr> <td>$L < 2.0$</td> <td>$W \leq 0.01$</td> <td>Ignore ①</td> </tr> <tr> <td>$L \geq 5.0$</td> <td>$W \leq 0.01$</td> <td>3</td> </tr> <tr> <td>$L \geq 3.0$</td> <td>$0.01 < W \leq 0.05$</td> <td>1</td> </tr> <tr> <td></td> <td>$W > 0.05$</td> <td>0</td> </tr> </tbody> </table> <p>2.0 Scratch for PCB</p> <table border="1" data-bbox="628 748 1256 954"> <thead> <tr> <th>Length</th> <th>Width</th> <th>Acceptable</th> </tr> </thead> <tbody> <tr> <td>$L > 3.0$</td> <td rowspan="2">$0.5 < W \leq 3.0$</td> <td>0</td> </tr> <tr> <td>$L \leq 3.0$</td> <td>1</td> </tr> <tr> <td>$L > 3.0$</td> <td rowspan="2">$W \leq 0.5$</td> <td>1</td> </tr> <tr> <td>$L \leq 3.0$</td> <td>3</td> </tr> </tbody> </table>	Length	Width	Acceptable	$L < 2.0$	$W \leq 0.01$	Ignore ①	$L \geq 5.0$	$W \leq 0.01$	3	$L \geq 3.0$	$0.01 < W \leq 0.05$	1		$W > 0.05$	0	Length	Width	Acceptable	$L > 3.0$	$0.5 < W \leq 3.0$	0	$L \leq 3.0$	1	$L > 3.0$	$W \leq 0.5$	1	$L \leq 3.0$	3
Length	Width	Acceptable																												
$L < 2.0$	$W \leq 0.01$	Ignore ①																												
$L \geq 5.0$	$W \leq 0.01$	3																												
$L \geq 3.0$	$0.01 < W \leq 0.05$	1																												
	$W > 0.05$	0																												
Length	Width	Acceptable																												
$L > 3.0$	$0.5 < W \leq 3.0$	0																												
$L \leq 3.0$		1																												
$L > 3.0$	$W \leq 0.5$	1																												
$L \leq 3.0$		3																												
5.0	Soldering appearance	Follow the requirements of IPC-060 for the soldering quality.																												

Criteria (functional items)

Number	Items	Criteria (mm)
1	Non operational	Fail
2	Miss operating	Fail
3	Missing dot	Fail
4	Contrast irregular	Refer to the limited sample



11.3 Safety instructions:

10.3.1 If the LCD panel breaks, be careful not to get the liquid crystal to touch you skin.

10.3.2 If the liquid crystal touches your skin or clothes, please wash it off immediately by using soap and water.

11.4 Handling

10.4.1 Avoid static electricity which can damage the LSI.

10.4.2 Do not remove the panel or frame from the module.

10.4.3 The polarizing plate of the display is very fragile. So, please handle it very carefully.

10.4.4 Do not wipe the polarizing plate with a dry cloth, as it may easily scratch the surface the plate.

10.4.5 Do not use ketonic solvent & aromatic solvent. Use a soft cloth soaked with a cleaning naphtha solvent.

10.4.6 The color tone of display and background on LCD has the possibility to be changed in the storage temperature range.

10.4.7 Pay attention to the working environment, as the element may be destroyed by static electricity.

--Be sure to ground human body and electric appliance during work.

--Avoid working in a dry environment to minimize the generations of static electricity.

--Static electricity may be generated when the protective film is fast peeled off.

11.5 Operation instructions:

It is recommended to drive the LCD within the specified voltage limits, try to adjust the operating voltage for the optimal contrast, the color and contrast of LCD panel will varies at different temperature, adjust the operating voltage for the optimal contrast.

The response time of the LC fluid is considerably longer response at low temperatures than that in the normal operating temperature range.

Do not operate the LCD at the environments over the specified conditions, this may cause damage on the LCD and shorten the lifetime.

11.6 Storage instructions:

10.6.1 Keep the LCD panel at a temperature of 15°C~35°C and at a relative humidity of 65% or less for long-term storage.

10.6.2 Keep the LCD panel away from high temperature (>40°C) and high humidity (>80%) environment for long-term storage.

10.6.3 Store away from direct sunlight and fluorescent light for long term storage, store the LCD panel in a dark place or cover it with black clothes, avoid to cover something or make marks on part of the LCD panel when exposing to light for long time.

10.6.4 Do not store the LCD panels in the environments over the specified storage conditions.



12. Packing method