

Tutorial of Maqueen Mechanic - Forklift

[ROB0156-F]

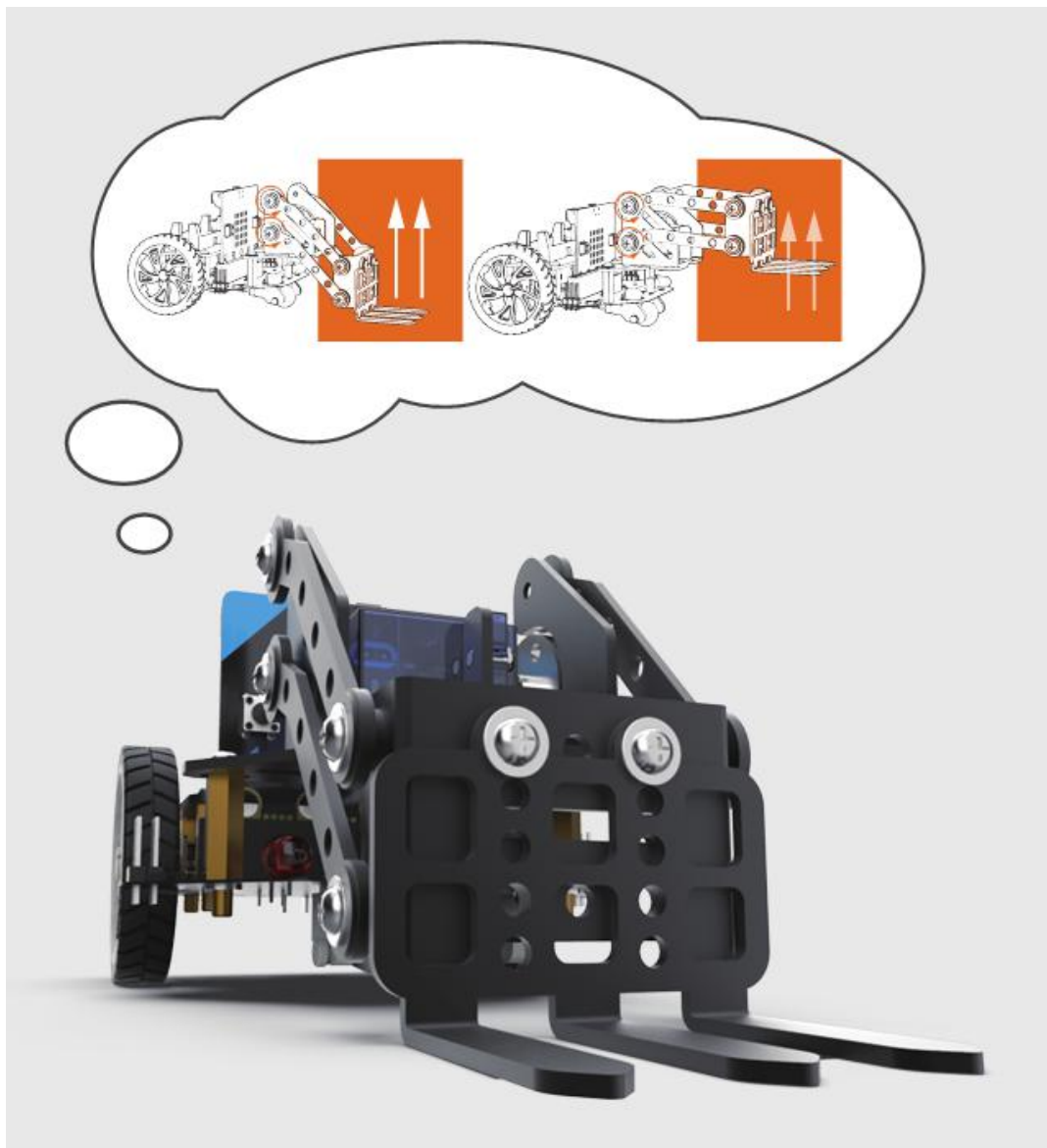

www.DFRobot.com

Installation Diagram

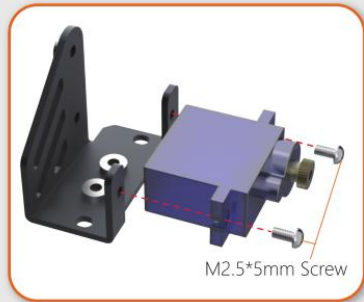

● Step1

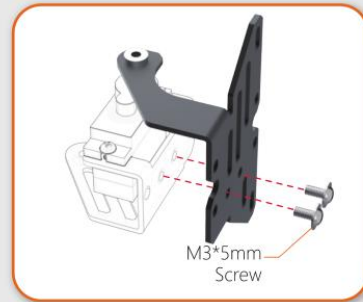

● Step2



● Step3

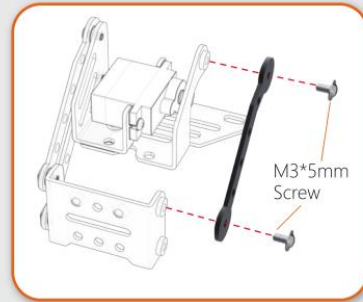

● Step4



● Step5

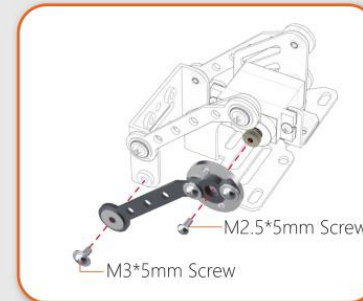

● Step6



● Step7



● Step8

Method to Control

1. Wiring

Plug the 3pin servo wire into port S1 or S2 of Maqueen, shown as below:

- Brown wire to Black pin
- Red wire to Red pin
- Orange wire to Green pin

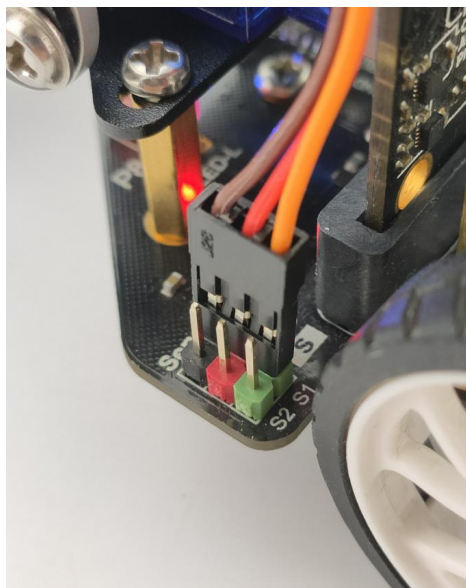

2. Makecode Tutorial

1. Click to open the Makecode programming web :

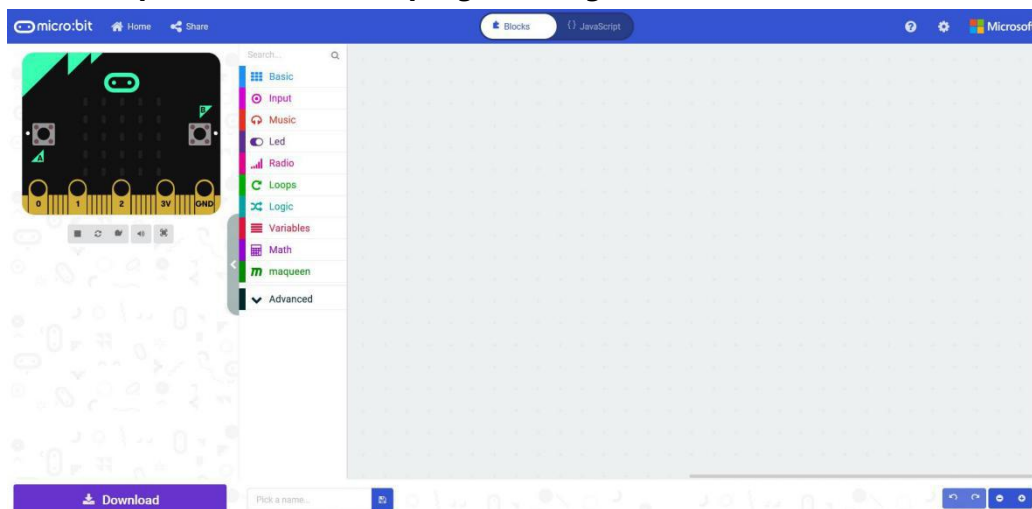

<https://makecode.microbit.org/#editor>

2. Import extensions for Maqueen:

- 1) Click **More**
- 2) Click **Extensions**
- 3) Search **dfrobot**
- 4) Click to select **Maqueen**

As shown in the figure:

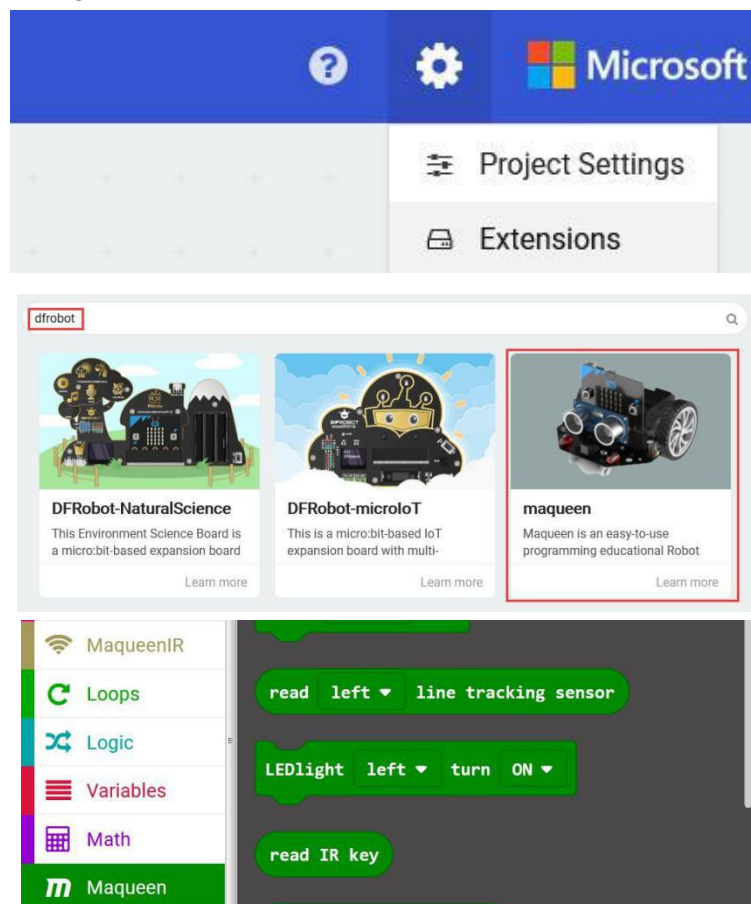

3. Examples

1. Move the fork up and down

- 1) The example will use a servo to make the forklift' s fork move up and down. The code is as follows:

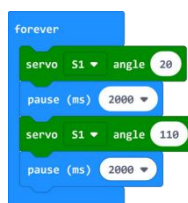

2) Connect the micro: bit to the computer via a USB cable. Meanwhile, a new "MICROBIT" disk will show in the computer. Click the "Download" button to download the code to MICROBIT disk. As shown in the figure:

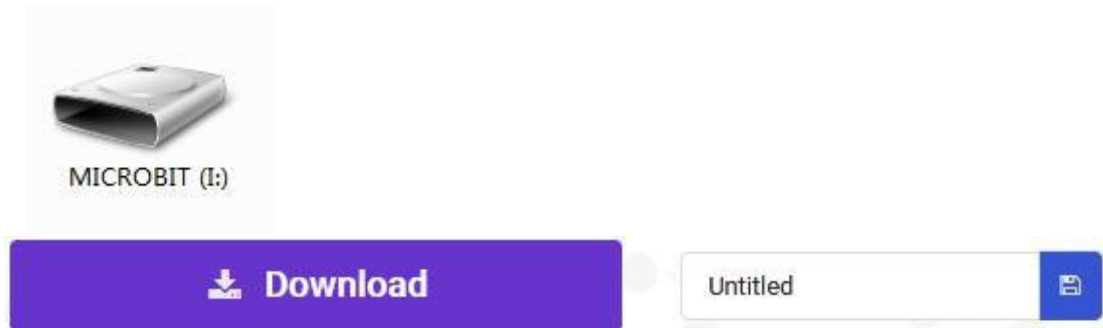

3) Turn Maqueen on when the example code is downloaded, then the forklift's fork will go up and down constantly.

There are two ways to adjust the starting and ending positions:

- Adjust the angle value in the code.
- Loosen the two screws on the servo and adjust the servo by hand, then tighten the screws. As shown in the figure:

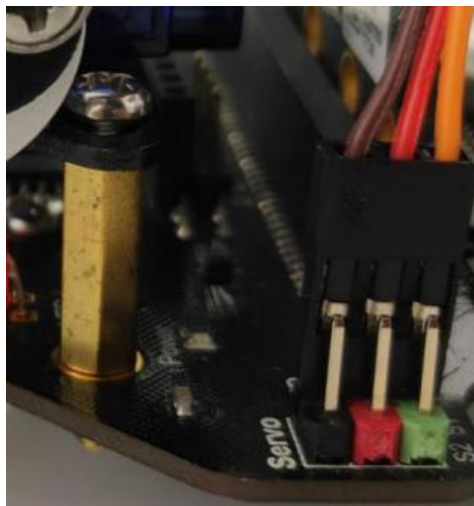

2. IR Remote control of the forklift

This example uses the infrared remote control to make the forklift's fork move up and down. Each button of the infrared remote control is corresponding to one key value.

Key	Key Value (Decimal)
Red Key	0
VOL+	1
FUNC/STOP	2
Rwd	4
Pause/Play	5
Fwd	6
Down Triangle	8
VOL-	9
Up Triangle	10
0	12
EQ	13
ST/REPT	14
1	16
2	17
3	18
4	20
5	21
6	22
7	24
8	25
9	26

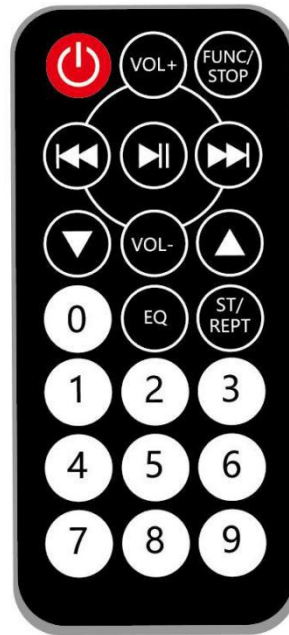

Key value table of infrared remote control

Now, let's program an example to control movement of the forklift's fork by the infrared remote control. The code is shown in the figure:

```

on IR received message
  if message = 8 then
    set S to S + 3
    servo S1 angle S
  if message = 10 then
    set S to S - 3
    servo S1 angle S
  6 / 8

on start
  set S to 90
  servo S1 angle S
  
```

After the code is downloaded to micro: bit, pointing the infrared remote control to the infrared receiver of Maqueen, holding the Up Triangle and the Down Triangle respectively, and the forklift' s fork will move up and down continuously.

3. IR Remote control of the Maqueen Mechanic- Forklift

In the two programs above, we have controlled the movement of the fork separately. The example below is a comprehensive program.

It uses the infrared remote control to enable the Maqueen move forward and backward and the fork move up and down.

Code URL: https://makecode.microbit.org/_D3bFyhgyYT7A

The code is shown as below:

```

on IR received message
  if message = 17 then
    motor all move Forward at speed 150
  +
  if message = 25 then
    motor all move Backward at speed 150
  +
  if message = 20 then
    motor left move Forward at speed 0
    motor right move Forward at speed 150
  +
  if message = 22 then
    motor left move Forward at speed 150
    motor right move Forward at speed 0
  +
  if message = 21 then
    motor all stop
  +
  if message = 8 then
    set S to S + 3
    servo S1 angle S
  +
  if message = 10 then
    set S to S - 3
    servo S1 angle S
  +

```

```

on start
  set S to 120
  servo S1 angle S

```

In this example, Keys 2, 8, 4, 6, 5 are used to control Maqueen to move forward, move backward, turn left, turn right and stop;

Using the Up and Down Triangles to make the forklift's fork move up and down respectively.